

BEFORE THE STATE ELECTRICITY REGULATORY COMMISSION,

SIKKIM

FILING NO. _____

CASE NO. P-01/Adj OF 2023

IN THE MATTER OF:

Shiga Energy Private Limited

...Petitioner

Versus

Government of Sikkim

...Respondent

MASTER INDEX

S. No.	Particulars	Page No.
1.	Index	
2.	Memo of Parties	
3.	List of Dates and Events	1-22
4.	Petition under Section 86(1)(f) of the Electricity Act, 2003 along with supporting affidavit and board resolution.	23-60
5.	<u>ANNEXURE 1:</u> True copy of the Implementation Agreement dated 03.09.2008.	61-79
6.	<u>ANNEXURE 2:</u> True copy of the Respondent's intimation dated 26.05.2009.	80-88
7.	<u>ANNEXURE 3:</u> True copy of the relevant extracts of the Minutes of Meeting along with its forwarding letter dated 03.01.2011 issued by PGCIL.	89-108
8.	<u>ANNEXURE 4:</u>	109-124

	True copy of the Long-Term Access Agreement dated 19.10.2011.	
9.	<u>ANNEXURE 5:</u> True copy of letter dated 23.01.2015 issued by the Petitioner to the Respondent.	125-126
10.	<u>ANNEXURE 6:</u> True copy of the Transmission Service Agreement dated 30.01.2014.	127-160
11.	<u>ANNEXURE 7 (COLLY.):</u> True copies of communication dated 05.03.2015, 18.03.2015, 07.04.2015, 21.04.2015, 23.06.2015, 05.08.2015 and 24.09.2015 addressed by the Petitioner.	161-167
12.	<u>ANNEXURE 8:</u> True copies of the Minutes of the Meeting dated 25.05.2015 along with its forwarding letter dated 02.07.2015.	168-198
13.	<u>ANNEXURE 9:</u> True copy of the communication from the Central Electricity Authority dated 04.11.2015.	199
14.	<u>ANNEXURE 10:</u> True copy of the relevant extracts of the Minutes of the Meeting dated 23.11.2015 along with the forwarding letter dated 24.11.2015 issued by the Central Electricity Authority.	200-204
15.	<u>ANNEXURE 11:</u> True copies of communication dated 29.12.2015 and 19.01.2016 addressed by the Petitioner.	205-206
16.	<u>ANNEXURE 12:</u> True copy of the relevant extracts of the	207-208

	Minutes of the Meeting dated 04.02.2016 along with the forwarding letter dated 19.02.2016 issued by the Central Electricity Authority.	
17.	<u>ANNEXURE 13:</u> True copy of the relevant extracts of the Minutes of the Meeting dated 08.02.2016 along with the forwarding letter dated 23.02.2016 issued by the Central Electricity Authority.	209-210
18.	<u>ANNEXURE 14:</u> True copy of the Minutes of the Meeting dated 16.02.2016 along with its forwarding letter dated 03.03.2016 issued by the Respondent.	211-213
19.	<u>ANNEXURE 15:</u> True copies of communication dated 02.03.2016 & 23.03.2016 addressed by the Petitioner.	214-216
20.	<u>ANNEXURE 16:</u> True copies of the Minutes of the Meeting dated 01.04.2016 along with the forwarding letter dated 06.04.2016.	217-220
21.	<u>ANNEXURE 17:</u> True copy of the communication dated 28.04.2016 addressed by the Petitioner.	221
22.	<u>ANNEXURE 18:</u> True copies of the relevant extracts of the Minutes of the Meeting dated 18.05.2016 along with the forwarding letter dated 30.05.2016 issued by Central Electricity Authority.	222-223
23.	<u>ANNEXURE 19:</u> True copies of the relevant extracts of the Minutes of the Meeting dated 10.06.2016 along with its forwarding letter dated 30.06.2016	224-225

	issued by Power Grid Corporation of India.	
24.	<u>ANNEXURE 20:</u> True copies of the relevant extracts of the Minutes of the Meeting dated 13.06.2016 along with the forwarding letter dated 19.08.2016 issued by the Central Electricity Authority.	226-228
25.	<u>ANNEXURE 21:</u> True copies of the letter dated 21.06.2016 addressed by the Petitioner to the Respondent.	229
26.	<u>ANNEXURE 22:</u> True copies of the relevant extracts of the Minutes of the Meeting dated 01.09.2016 along with its forwarding letter dated 24.10.2016 issued by Respondent.	230-232
27.	<u>ANNEXURE 23:</u> True copies of the Minutes of the Meeting dated 30.09.2016 along with the forwarding letter dated 24.10.2016.	233-234
28.	<u>ANNEXURE 24 (COLLY.):</u> True copies of the Petitioner's communication dated 03.10.2016 and 13.10.2016.	235-237
29.	<u>ANNEXURE 25:</u> True copies of the relevant extracts of the Minutes of the Meeting dated 04.10.2016 along with the forwarding letter dated 13.10.2016 issued by the Central Electricity Authority.	238-240
30.	<u>ANNEXURE 26:</u> True copy of the communication dated 20.10.2016 addressed by the Central Electricity Authority.	241
31.	<u>ANNEXURE 27:</u> True copies of the relevant extracts of the	242-243

	Minutes of the Meeting dated 03.11.2016 along with the forwarding letter dated 09.11.2016 issued by the Central Electricity Authority.	
32.	<u>ANNEXURE 28:</u> True copy of communication dated 07.11.2016 addressed by the Petitioner.	244
33.	<u>ANNEXURE 29:</u> True copy of communication dated 08.11.2016 addressed by the Petitioner.	245
34.	<u>ANNEXURE 30:</u> True copies of the Minutes of the Meeting dated 16.11.2016 along with the forwarding letter dated 5.12.2016.	246-249
35.	<u>ANNEXURE 31:</u> True copy of the communication dated 29.11.2016 addressed by Respondent.	250
36.	<u>ANNEXURE 32:</u> True copy of the communication dated 12.12.2016 addressed by the Petitioner.	251
37.	<u>ANNEXURE 33:</u> True copies of the relevant extracts of the Minutes of the Meeting dated 27.12.2016 along with the forwarding letter dated 02.02.2017 issued by Power Grid Corporation of India.	252-253
38.	<u>ANNEXURE 34:</u> True copy of communication dated 29.12.2016 addressed by the Petitioner.	254
39.	<u>ANNEXURE 35:</u> True copy of communication dated 04.01.2017 addressed by the Petitioner.	255
40.	<u>ANNEXURE 36:</u> True copy of communication dated 17.01.2017	256

	addressed by the Petitioner.	
41.	<u>ANNEXURE 37:</u> True copy of the communication dated 23.01.2017 addressed by the Petitioner to the Central Electricity Authority.	257
42.	<u>ANNEXURE 38:</u> True copy of the communication dated 06.02.2017 addressed by the Petitioner to the Respondent.	258
43.	<u>ANNEXURE 39:</u> True copies of the Minutes of the Meeting dated 13.02.2017 along with its forwarding letter dated 21.02.2017 issued by Central Electricity Authority.	259-261
44.	<u>ANNEXURE 40:</u> True copies of the relevant extract of the Minutes of Meeting dated 27.03.2017 along with its forwarding letter dated 09.05.2017 issued by Power Grid Corporation of India.	262-263
45.	<u>ANNEXURE 41:</u> True copy of the communication dated 28.03.2017 addressed by the Petitioner to the Respondent.	264
46.	<u>ANNEXURE 42:</u> True copy of the communication dated 03.04.2017 addressed by the Petitioner to the Respondent.	265
47.	<u>ANNEXURE 43 (COLLY.):</u> True copies of the communications dated 10.04.2017, 13.04.2017 and 01.05.2017 addressed by the Petitioner.	266-269
48.	<u>ANNEXURE 44:</u>	

	True copies of the relevant extracts of the Minutes of the Meeting dated 16.06.2017 along with the forwarding letter dated 08.08.2017 issued by Power Grid Corporation of India.	270-273
49.	<u>ANNEXURE 45:</u> True copy of the communication dated 28.04.2017.	274
50.	<u>ANNEXURE 46 (COLLY.):</u> True copies of the communication dated 02.06.2017 and 09.08.2017.	275-278
51.	<u>ANNEXURE 47:</u> True copy of the communication dated 19.06.2017 addressed by the Petitioner.	279
52.	<u>ANNEXURE 48:</u> True copy of communication dated 21.06.2017 addressed by Power Grid Corporation of India.	280-282
53.	<u>ANNEXURE 49:</u> True copy of the communication dated 18.08.2017 addressed by the Petitioner.	283-284
54.	<u>ANNEXURE 50:</u> True copy of the Connection Agreement dated 04.09.2017.	285-290
55.	<u>ANNEXURE 51 (COLLY.):</u> True copies of relevant extracts of the Minutes of Meeting dated 13.09.2017 and 14.09.2017.	291-297
56.	<u>ANNEXURE 52:</u> True copy of the Letter dated 25.09.2017.	298
57.	<u>ANNEXURE 53 (COLLY.):</u> True copies of the communication dated 25.09.2017 and 26.09.2017 addressed by Petitioner to the Electrical Inspectorate, Government of Sikkim.	299-306

58.	<u>ANNEXURE 54:</u> True copy of the communication dated 26.09.2017 addressed by the Respondent to the Chief Technical Advisor of the Petitioner.	307-308
59.	<u>ANNEXURE 55:</u> True copy of communication dated 10.10.2017 addressed by the Power Grid Corporation of India. .	309
60.	<u>ANNEXURE 56:</u> True copy of communication dated 06.11.2017 addressed to Central Electricity Authority.	310-311
61.	<u>ANNEXURE 57:</u> True copy of the petition filed by the Petitioner before the Ld. Central Electricity Regulatory Commission (Without Annexures).	312-350
62.	<u>ANNEXURE 58:</u> True copy of the order dated 08.12.2021 issued by the Ld. Central Electricity Regulatory Commission.	351-367
63.	<u>ANNEXURE 59:</u> True Copy of the Letter dated 16.12.2022 to this Hon'ble Commission stating, <i>inter-alia</i> , the losses suffered by the Petitioner due to the delay in completion of the transmission line from Tashiding- Pooling Station to New Melli Pooling Station.	368-412
64.	<u>ANNEXURE 60:</u> True copy of the letter dated 21.01.2023 by this Hon'ble Commission, replying to the letter dated 16.12.2022 of the Petitioner.	413
65.	<u>ANNEXURE 61: (COLLY.):</u> True copy of the computation chart of the	414-666 and

	financial loss along with the supporting documents, namely 'Detailed Project Report' of March 2009 and 'Project Information Memorandum' of October 2011 as also the month wise rate at 'Indian Energy Exchange' for the relevant period i.e., January 2017 to October 2017.	667-965 and 966-1193
66.	<u>ANNEXURE 62:</u> True copy of the certificate dated May 15, 2023 issued by B Luthra Associates, Chartered Accountants, certifying the losses to the Petitioner, for the relevant period, i.e. January 2017 to October 2017.	1194

Through: 

**Hardeep Sachdeva/ Kamal Shankar/ Abhyudai Singh/
Swati Sharma/ Tushar Dutta/ Devyani Jewel/
Maaz Ahmed**

**Counsels For the Petitioner
AZB & Partners**

A-8, Sector 4, Noida, Uttar Pradesh

Email Id: abhyudai.singh@azbpartners.com

Phone No: +91-9968821409

Place: New Delhi

Date: _____ .08.2023

BEFORE THE STATE ELECTRICITY REGULATORY COMMISSION,
SIKKIM

FILING NO. _____

CASE NO. P-01/Adj OF 2023

IN THE MATTER OF:

Shiga Energy Private Limited

...Petitioner

Versus

Government of Sikkim

...Respondent

INDEX VOLUME I

S. No.	Particulars	Page No.
1.	Index	
2.	Memo of Parties	
3.	List of Dates and Events	1-22
4.	Petition under Section 86(1)(f) of the Electricity Act, 2003 along with supporting affidavit and board resolution.	23-60

Through: 

Hardeep Sachdeva/ Kamal Shankar/ Abhyudai Singh/
Swati Sharma/ Tushar Dutta/ Devyani Jowel/
Maaz Ahmed

Counsels For the Petitioner
AZB & Partners

A-8, Sector 4, Noida, Uttar Pradesh

Email Id: abhyudai.singh@azbpartners.com

Phone No: +91-9968821409

Place: New Delhi

Date: _____ .08.2023

**BEFORE THE STATE ELECTRICITY REGULATORY COMMISSION,
SIKKIM**

FILING NO. _____

CASE NO. P-01/Adj OF 2023

IN THE MATTER OF:

Shiga Energy Private Limited

...Petitioner

Versus

Government of Sikkim

...Respondent

LIST OF DATES AND EVENTS

S. NO.	DATE	PARTICULARS
1.	03.09.2008	The Petitioner and Respondent entered into an Implementation Agreement for <i>inter alia</i> setting up and operating a Hydro Electric Project in Tashiding District in the state of Sikkim on Rangit river of a capacity of 2 x 48.5 MW (" THEP " or " Project ").
2.	26.05.2009	Power Grid Corporation of India Limited (" PGCIL ") communicated to the Petitioner its intention to grant Long Term Open Access to the Petitioner for evacuation of power from the Project.
3.	28.12.2010	A meeting was held amongst the Petitioner, PGCIL and other project developers, wherein, it was, <i>inter alia</i> , agreed that the responsibility of the Petitioner was limited to the Transmission System (drawl line) up to the Tashiding pooling station near Tashiding 220KV D/c line and the <u>Transmission Line from Tashiding pooling station to New Melli pooling</u>

S. NO.	DATE	PARTICULARS
		<u>station shall be taken within the scope of work of the Respondent.</u>
4.	19.10.2011	Petitioner and PGCIL entered into a Long-Term Access Agreement (“LTAA”) for the purpose of granting long term access to the Petitioner as a long-term transmission consumer in accordance with the Central Electricity Regulatory Commission (Grant of Connectivity, Long Term Access and Medium-Term Open Access in Inter State Transmission and Related Matters) Regulations, 2009.
5.	2011 – 2014	Certain Writ Petitions were filed by the local residents before the Hon’ble Supreme Court of India against the implementation and execution of the THEP.
6.	30.01.2014	Petitioner and PGCIL entered into a Transmission Service Agreement (“TSA”) to govern the provisions of the inter-state transmission services.
7.	10.10.2014	The Ministry of Power, Government of Sikkim, vide letter no. F.NO.3/23/2011-Trans conveyed its approval for comprehensive scheme for strengthening of transmission and distribution system in the states of Arunachal Pradesh and Sikkim.
8.	23.01.2015	The Petitioner sent a letter to the Respondent apprising the Respondent of the extension of the Commercial Operations Date (“COD”) of THEP as a

S. NO.	DATE	PARTICULARS
		result of the orders passed by the Hon'ble High Court of Sikkim in the Writ Petitions.
9.	22.04.2015	A Memorandum of Understanding (“MOU”) was executed between Respondent and PGCIL pursuant to which PGCIL was appointed as an agent and ‘Project Management Consultant’ for the Respondent.
10.	05.03.2015, 18.03.2015, 07.04.2015, 21.04.2015, &	Since PGCIL was appointed by the Respondent for executing the transmission related works for and on behalf of the Respondent, a series of communication were sent by the Petitioner to PGCIL <i>inter alia</i> informing PGCIL, that the expected COD is in December 2016 and requested PGCIL to expeditiously carry out, work related to the construction of the Legship substation and the Transmission line from Legship to New Melli on priority basis to avoid any delay in power evacuation of THEP. A copy of the letter dated 24.09.2015 was also sent to the Respondent for its attention.
11.	25.05.2015	A meeting was held, <i>inter alia</i> , amongst PGCIL and the Respondent, wherein it recorded the specific request of the Petitioner to expedite the implementation of the Legship substation and Legship – New Melli Transmission line.
12.	23.06.2015 and 05.08.2015	Communications were sent by the Petitioner to PGCIL <i>inter alia</i> informing PGCIL, that the expected COD is in December 2016 and requested PGCIL to

S. NO.	DATE	PARTICULARS
		expeditiously carry out, work related to the construction of the Legship substation and the Transmission line from Legship to New Melli on priority basis to avoid any delay in power evacuation of THEP.
13.	24.09.2015	Another communication was sent by the Petitioner to PGCIL whereby PGCIL was informed that the COD is expected in December 2016 and it was further requested that PGCIL to expeditiously carry out work related to the construction of Legship substation.
14.	04.11.2015	Taking note of the fact that PGCIL had not yet awarded the construction works of the Legship substation and Legship – New Melli Transmission line and that THEP was expected to achieve commissioning of the Project by December, 2016, the Central Electricity Authority (“CEA”) sent a communication to PGCIL requesting PGCIL to start construction work at the earliest in order to complete the Transmission line and the pooling station in the same time frame of the generation project.
15.	23.11.2015	A meeting was held with the CEA, wherein it was, <i>inter alia</i> , recorded that PGCIL had agreed to expedite the commissioning of the Legship pooling station and Legship – New Melli Transmission line to match with the commissioning schedule of the Project, viz. expected COD of December 2016.

S. NO.	DATE	PARTICULARS
16.	29.12.2015 and 19.01.2016	The Petitioner sent notices to CEA and PGCIL, requesting the works in relation to the Legship – New Melli Transmission line be completed with the completion of the Project.
17.	04.02.2016	A meeting was held with the CEA, wherein it was, <i>inter alia</i> , recorded that PGCIL (on behalf of the Respondent) was to take up construction of the Legship to New Melli Transmission line at the earliest.
18.	08.02.2016	A meeting was held with the CEA, wherein it was, <i>inter alia</i> , noted that the Petitioner requested to PGCIL, as an agent of the Respondent to complete the Legship pooling station and the Legship to New Melli Transmission line by September 2016.
19.	16.02.2016	In the 8 th Meeting of Joint Coordination Committee for High-Capacity Corridor for IPPs in Eastern Region the Joint Coordination Committee recorded that the Transmission system under the scope of the Respondent was to be expedited.
20.	02.03.2016 and 23.03.2016	Notices were sent by the Petitioner to PGCIL, informing that the works in relation to Legship substation, Legship to New Melli Transmission line and the associated 2 Nos GIS Bays at New Melli have not yet been awarded by PGCIL.
21.	01.04.2016	A meeting was held with the CEA, wherein it was, <i>inter alia</i> , observed that owing to the delay of PGCIL

S. NO.	DATE	PARTICULARS
		in awarding the Transmission line projects in relation to THEP, the Petitioner requested for an interim arrangement, i.e., Transmission line from THEP to Legship pooling station and Transmission line from Legship pooling station to New Melli substation be directly connected by bypassing the Legship pooling station to evacuate power from THEP. Further, the CEA requested PGCIL to expedite the construction of Legship substation and Legship to New Melli Transmission line.
22.	28.04.2016	A notice was sent by the Petitioner to the Respondent stating that PGCIL has not yet awarded the works for the Legship to New Melli Transmission line and that the Petitioner would have to bear an expenditure of Rs. 10 crores for each month for the delay in evacuation of power after completion of THEP towards interest to project lenders and overheads.
23.	18.05.2016	A meeting was held with the CEA, wherein it was, <i>inter alia</i> , recorded that the Petitioner has made relentless and repeated requests for completion of the Transmission works within the scope of the work of the Respondent which were still not completed.
24.	10.06.2016	In the Meeting of the 9 th Meeting of Joint Coordination Committee for High Capacity Corridor for IPPs in Eastern Region it was, <i>inter alia</i> , recorded that the Transmission system under the scope of work of the Respondent was to be expedited.

S. NO.	DATE	PARTICULARS
25.	13.06.2016	In the Meeting of the 18 th Standing Committee of Power System Planning of Eastern Region the interim arrangement between the Petitioner and PGCIL was reaffirmed. Further, an additional interim arrangement was entered into whereby if the bays at New Melli for termination of Legship – New - Melli 220 KV D/c line are not ready, then a LILO of one circuit of New Melli – Rangpo 220 KV D/c line be implemented at a suitable location near New Melli with the same being further connected with Tashiding – New Melli line so as to form Tashiding – New Melli, Tashiding - Rangpo and New Melli - Rangpo 220 KV S/c lines.
26.	21.06.2016	A notice was sent by the Petitioner to Respondent seeking information to be furnished for signing of the Connection Agreement to intra-state transmission system and requesting the Respondent to consider the Petitioner's case on top priority basis as THEP would be ready for commissioning by December 2016.
27.	01.09.2016	A meeting was held with the CEA, wherein it was observed that the Petitioner had again requested for expediting Transmission line works under the scope of the Respondent and had also sought the Respondent's intervention.

S. NO.	DATE	PARTICULARS
28.	30.09.2016	In the Meeting of the 10 th Meeting of Joint Coordination Committee for High-Capacity Corridor for IPPs in Eastern Region, the Committee took note of the fact that the Transmission line works under the scope of work of the Respondent needed to be expedited.
29.	03.10.2016	A notice was sent by the Petitioner to CEA highlighting the importance of completion of Transmission line works falling under the scope of work of the Respondent in line with completion of THEP, to avoid a loss of 1.17 million units of clean energy every day and the increase in Interest During Construction (“IDC”) to the lenders of the project which would render THEP unviable.
30.	13.10.2016	The Petitioner sent a letter to the Respondent stating that the Petitioner has been given to understand that the contract for the Transmission line from Legship station to New Melli substation has been placed on M/s KEC by the Respondent’s agent PGCIL on 27.07.2016. The Petitioner further stated that the timely completion of the Transmission line up to New Melli substation is very urgent as the Project commissioning is scheduled by the end of December 2016. The Petitioner requested for support and cooperation from the Respondent to ensure that the balance portion of the line from Legship substation to New Melli substation required for power evacuation from the Project be completed to match

S. NO.	DATE	PARTICULARS
		with the commissioning schedule of THEP by December 2016.
31.	04.10.2016	A meeting was held with the CEA, wherein it was, <i>inter alia</i> , observed that PGCIL, had much belatedly awarded the construction of approximately 10 k.m. Transmission line (Legship to New Melli line) in July 2016 to M/s KEC with incomplete detailed survey and M/s KEC was advised by the Chief Engineer to submit an action plan within 1 week for completion of transmission line by 15.12.2016 and submit weekly reports of the status of the progress thereafter.
32.	20.10.2016	Communication was sent by CEA to PGCIL, with a copy to the Respondent, recording that M/s KEC has not submitted an action plan and requesting PGCIL, to look into the matter in order to ensure that construction of Legship to New Melli Transmission line is done on a priority basis and THEP gets commissioned as per schedule.
33.	03.11.2016	A meeting was held with the CEA, wherein it was, <i>inter alia</i> , recorded that the Petitioner has completed the civil works, E&M works and MIV Installation and that the testing of units along with its likely commissioning shall be done in December 2016. Further, it was noted that the main constraint is Transmission works, for which intervention of the Respondent is needed, and the Transmission line

S. NO.	DATE	PARTICULARS
		within the scope of work of the Respondent needs to be completed by December 2016.
34.	07.11.2016	A letter was sent by the Petitioner to the Respondent highlighting the poor progress of works on the Transmission lines falling within the scope of work of the Respondent and stressing the importance of timely completion of Transmission lines up to New Melli substation being critical to the evacuation of power from the Project by December 2016/ January 2017.
35.	08.11.2016	A notice was sent by the Petitioner informing the Respondent of the lack of progress of works and reiterating the importance of completion of the Transmission line works as being critical for evacuation of power from the Project.
36.	16.11.2016	A meeting was held with the CEA, wherein it was, <i>inter alia</i> , recorded that the Petitioners scope of work will be ready by December 2016. PGCIL informed that the following were required to be resolved at the earliest to expedite the completion of the Project: (a) Road permit by the Respondent is awaited; and (b) Non-availability of TAN No. from the Respondent.
37.	23.11.2016	A reminder was sent by the Petitioner to the Respondent to furnish requisite information requested by the Petitioner vide communication dated 21.06.2016.

S. NO.	DATE	PARTICULARS
38.	29.11.2016	Communication was sent by PGCIL informing the Petitioner that the Respondent never placed an order to execute the Transmission line from the Legship pooling station to the New Melli pooling station in September 2014. PGCIL further stated that after the award of contract, initially there was a delay of 2-3 months due to commercial issues like road permit, TAN no., etc. which are attributable to the Respondent. PGCIL further stated that efforts were being made to complete the Transmission line by March 2017.
39.	12.12.2016	Communication was sent by the Petitioner to PGCIL, stating that the urgency of the scheduled commissioning of THEP was highlighted on numerous occasions and that the non-completion of Transmission line from Legship to New Melli would result in a loss of approximately Rs. 10 crores per month towards additional Interest During Construction besides loss of revenue against sale of power.
40.	27.12.2016	Relevant extracts of the Minutes of Meeting of the 11 th Joint Coordination Committee for High-Capacity Corridor for IPPs in Eastern Region and forwarding letter dated 02.02.2017 issued by PGCIL. The 11 th Joint Coordination Committee recorded that it was imperative that the Transmission system falling

S. NO.	DATE	PARTICULARS
		under the scope of work of the Respondent should be expedited.
41.	29.12.2016	A notice was sent by the Petitioner informing PGCIL that the dry commission of one unit of THEP is complete, the second unit and Transmission line for THEP to Legship substation shall be completed by December 2016. Further, the Petitioner also apprised PGCIL, acting as an agent of the Respondent, that it is critical that the Transmission line from Legship to New Melli being built by PGCIL is completed by January 2017, to enable the evacuation of power from THEP.
42.	04.01.2017	A notice was sent by the Petitioner to the CEA with a copy to the Respondent and PGCIL, notifying the completion of dry commissioning of both units and construction of Transmission line from THEP to Legship substation and requesting PGCIL for completion of Transmission line from Legship to New Melli. The Petitioner also stated that power from the Project is ready for evacuation and can be evacuated once the Transmission line from Legship to New Melli being built by the Respondent/ PGCIL/ M/s KEC is completed. It was further requested that the said Transmission line which was required for power evacuation be completed at the earliest.
43.	17.01.2017	A notice was sent by the Petitioner to the Respondent reiterating that failure of completion of Transmission

S. NO.	DATE	PARTICULARS
		works falling under the scope of work of the Respondent shall result in a loss by virtue of the additional interest burden to the extent of Rs. 10 crores per month on the Petitioner.
44.	23.01.2017	A notice was sent by the Petitioner to CEA stating that the dry commissioning of both the units as well as the 220 KV D/c Transmission line from Tashiding HEP to Legship substation has been successfully completed. The Petitioner further reiterated that the evacuation of power can only be achieved if the Transmission line from Legship substation to New Melli substation can be immediately completed by the Respondent/ PGCIL/ M/s KEC and therefore the completion of the said Transmission line is critical, failing which there will be loss of green power and revenue as well as an additional interest burden on the Petitioner of approximately Rs. 7 crores per month.
45.	06.02.2017	A notice was sent by the Petitioner to Chief Electrical Inspector of the Respondent, requesting the issuance of Clearance Certificate for First Charging as the entire installation of the powerhouse, sub-station, switchyard and 220KV D/c Transmission line has been constructed and tested.
46.	13.02.2017	A meeting was held with the CEA, wherein it was, <i>inter alia</i> , noted that PGCIL, acting as an agent of the Respondent, has failed to start the construction of

S. NO.	DATE	PARTICULARS
		the Legship pooling station despite stating that construction shall be complete by March 2017.
47.	27.03.2017	In the Meeting of the 12 th Meeting of the Joint Coordination Committee for High-Capacity Corridor for IPPs in Eastern Region, the Joint Coordination Committee noted that the Transmission line work under the scope of work of the Respondent is to be expedited for completion which is expected by May 2017.
48.	28.03.2017	Communication by Ex Chief Engineer, CEA to the Petitioner stating that the Transmission line of the Petitioner is ready but it is yet to be terminated at the Legship pooling point of PGCIL.
49.	03.04.2017	Item Wise Compliance Report was submitted by the Petitioner stating that the PLCC Test and Fault Locator Test can only be performed after both the ends of the Transmission line are properly terminated/ connected.
50.	10.04.2017, 13.04.2017 and 01.05.2017	Notices were sent by the Petitioner to the Respondent highlighting the status of work falling under the scope of work of the Respondent as half completed thereby resulting in generation/ revenue loss of more than Rs. 100 crores to the Petitioner.
51.	28.04.2017	Communication by the Chief Electrical Inspector of the Respondent to the Petitioner granting statutory approval for first charging of the THEP.

S. NO.	DATE	PARTICULARS
52.	02.06.2017 and 09.08.2017	Reminders were sent by the Petitioner to the Respondent to provide clarity on the information required to be furnished for signing Connection Agreement.
53.	16.06.2017	In the 13 th Meeting of Joint Coordination Committee for High Capacity Corridor for IPPs in Eastern Region it was, <i>inter alia</i> , recorded that the COD of the Project was waiting on account of the non-commissioning of Legship to New - Melli Transmission line and Bays at New - Melli under the scope of work of the Respondent, which was now expected by August 2017.
54.	19.06.2017	A notice was sent by the Petitioner requesting PGCIL, acting as an agent of the Respondent to provide current status of the Transmission line works from Legship to New- Melli substation along with target date of completion.
55.	21.06.2017	Communication was sent by PGCIL, acting as agent of the Respondent, in utter breach and disregard of its previous commitment, stating that the expected date of completion of the Transmission line works is 15.07.2017.
56.	18.08.2017	A notice was sent by the Petitioner informing the Respondent of the failure to complete the Transmission line works and that the continuous

S. NO.	DATE	PARTICULARS
		and repeated breaches has resulted in the Petitioner accruing losses, including generation loss and Interest During Construction from January 2017 onwards. The Petitioner further stated that it has already lost revenue of around Rs. 100 crores from January 2017 to end of August 2017 due to non-completion of the Transmission line, and in case Transmission line completion is extended to end of September, the additional revenue loss of around Rs. 23 crores will be incurred. The Petitioner also informed the Respondent that the Project has become a stressed asset due to non-completion of the said Transmission line.
57.	04.09.2017	A connection agreement entered into between Petitioner and the Respondent for connection of the 220 kV D/c of THEP.
58.	13.09.2017 and 14.09.2017	In the Meeting of 36 th Technical Coordination/ Eastern Regional Power Committee and members of the TCC, it was recorded that the Interim Agreement on account of anticipated delay in commissioning of Legship Pooling Station and 2 No. 220 GIS Bays at New Melli substation.
59.	25.09.2017	Letter was sent by the Electrical Inspectorate to the Respondent noting that the Transmission Line of THEP under the Petitioner's scope of work is ready and temporarily connected to Tower 1 of Powergrid, to be terminated at the pooling point at New Melli of

S. NO.	DATE	PARTICULARS
		Powergrid revealing the delay on part of PGCIL, acting as an agent of the Respondent in executing transmission assets.
60.	25.09.2017 and 26.09.2017	Communication was sent by the Petitioner to the Electrical Inspectorate of the Respondent stating, <i>inter alia</i> , that the Petitioner has complied with the instructions of the Electrical Inspectorate in communication dated 25.09.2017 and has removed the bamboo, debris and mud from the tower footings.
61.	26.09.2017	Communication was sent by Respondent to the Petitioner approving the energizing of 220kV Double Circuit Transmission Line of 2 x 48.5 MW, THEP as required under Regulation 43 of the Central Electricity Authority (Measures Related to Safety and Electric Supply) Regulations, 2010.
62.	10.10.2017	Communication was sent by PGCIL intimating the Petitioner, after gross and inordinate delay that construction of the 220 KV D/c Legship Pool (Tingmoo) to New Melli Transmission line is completed.
63.	06.11.2017	Communication was sent by the Petitioner to the CEA that COD of both units of THEP is declared.
64.	27.11.2017	Communication was sent by the Petitioner to PGCIL seeking payment of Rs. 112.39 crore as compensation for financial loss suffered by the

S. NO.	DATE	PARTICULARS
		Petitioner due to the delay in completion of the transmission line works with a copy to the Respondent.
65.	28.02.2018	A petition was filed by the Petitioner under section 79(1)(c) read with section 79(1)(f) of the Electricity Act, 2003 before the Hon'ble Central Electricity Regulatory Commission seeking, <i>inter alia</i> , from PGCIL an amount of Rs. 112.39 crore as financial loss suffered by the Petitioner, on account of delay in commencement of the Long-Term Access granted to the Petitioner, due to delay in implementation of the transmission system and in the alternative, seeking a sum of Rs. 101.59 crores being the Interest During Construction charges levied on the Petitioner by its lenders as also the preliminary and pre-operative expenses and additional claims of the contracts engaged in the Project on account of delay of the Transmission System.
66.	28.02.2018	An application bearing I.A. No. 15/2018 filed by the Petitioner under Section 79(1)(f) read with section 158 of the Electricity Act, 2003 before the Hon'ble Central Electricity Regulatory Commission seeking reference of the disputes to Arbitration.
67.	07.08.2018	A notice of I.A. No. 15/2018 issued to PGCIL <i>vide</i> the order of the Hon'ble Central Electricity Regulatory Commission.

S. NO.	DATE	PARTICULARS
68.	15.12.2018	A reply was filed by PGCIL in Petition No. 92/MP/2018 <i>inter alia</i> stating that PGCIL was merely acting as agent of the Respondent in terms of the Memorandum of Understanding 22.04.2015.
69.	02.01.2019	An application bearing I.A No. 9/ 2019 filed by the Petitioner seeking amendment of the Petition No. 92/MP/2018 for claiming the damages from the Respondent.
70.	15.03.2019	A reply filed by the PGCIL to the Application filed by the Petitioner seeking amendment of the Petition No. 92/MP/2018 (I.A. No. 9/2019).
71.	23.03.2019	A rejoinder was filed by the Petitioner to the reply filed by PGCIL to application seeking amendment of the Petition No. 92/MP/2018. (I.A. No. 9/2019).
72.	29.03.2019	A rejoinder was filed on behalf of the Petitioner to the reply filed by PGCIL to the application seeking amendment of the Petition No. 92/MP/2018
73.	14.10.2019	A rejoinder filed by the Petitioner to the reply filed by PGCIL to the Petition No. 92/MP/2018.
74.	10.12.2019	A reply affidavit filed by the Respondent through Energy and Power Department in Petition No. 92/MP/2018.

S. NO.	DATE	PARTICULARS
75.	23.12.2019	A rejoinder filed by the Petitioner to the reply filed by the Respondent in Petition No. 92/MP/2018.
76.	11.03.2020	An application was filed by the Petitioner praying for listing of Petition No. 92/MP/2018 before a bench not comprising of Sh. I.S. Jha, Hon'ble Member.
77.	26.08.2020	Written note of submissions were filed by the Petitioner in Petition No. 92/MP/2018.
78.	25.06.2021	Hon'ble Central Electricity Regulatory Commission heard arguments in I.A. No. 15/2018 and granted further time to the PGCIL to file its reply.
79.	10.09.2021	A reply was filed by PGCIL in I.A. No. 15/2018 after repeated reminders and emails by the Petitioner.
80.	17.09.2021	A rejoinder was filed by the Petitioner to the reply filed by PGCIL to I.A. No. 15/2018 preferred on behalf of the Petitioner seeking reference of the disputes raised in the Petition No. 92/MP/2018 to Arbitration.
81.	06.06.2022	An Order was passed by the Hon'ble Central Electricity Regulatory Commission (" CERC ") <i>inter alia</i> directing the Petitioner to approach the Hon'ble State Electricity Regulatory Commission for the compensation claimed by the Petitioner from the Respondent in relation to the delay of transmission assets. It was observed by the CERC that the assets under dispute (Legship pooling station and

S. NO.	DATE	PARTICULARS
		<p>transmission line from Legship to New Melli) were originally under the scope of the Petitioner as a dedicated transmission system. However, the scope of work was later revised and the said assets under dispute were under the scope of work of the Respondent. It was held by the CERC that the said transmission assets under dispute came under the scope of the Respondent and the jurisdiction of any dispute vis a vis the said dispute lies with the concerned State Commission.</p> <p>The relevant extracts are reproduced below:</p> <p><i>“37. The Petitioner vide the amended petition has claimed compensation from the Respondent No.2, Government of Sikkim for delay of transmission assets. We observe from the LTA intimation that the assets under dispute (Legship pooling station and transmission line from Legship to New Melli) were originally under the scope of the Petitioner as a dedicated transmission system. Respondent No. 2 has submitted that it was the Petitioner, who citing difficulty in constructing the said transmission system, requested Government of Sikkim to get it included in the comprehensive scheme. This implies that the assets came under the scope of Government of Sikkim subsequently as recorded in the LTA Agreement. We observe that the transmission assets under dispute are a part of intra-state transmission system. The Petitioner has entered into Connection</i></p>

S. NO.	DATE	PARTICULARS
		<p><i>Agreement with the Power department, Government of Sikkim on 4.9.2017. We observe that the jurisdiction for any dispute vis-a-vis the intra-state transmission system lies with the concerned State Commission. Therefore, the Petitioner is at liberty to approach the Appropriate Commission for adjudication of the dispute relating to the intra-state transmission system."</i></p>

BEFORE THE STATE ELECTRICITY REGULATORY COMMISSION,
SIKKIM

FILING NO. _____

CASE NO. P-01/Adj OF 2023

IN THE MATTER OF:

Shiga Energy Private Limited

...Petitioner

Versus

Government of Sikkim

...Respondent

PETITION UNDER SECTION 86(1)(F) OF THE ELECTRICITY ACT, 2003

MOST RESPECTFULLY SHOWETH:

1. The Petitioner, Shiga Energy Private Limited, is a company incorporated under the provisions of the Companies Act, 1956, having its registered office at B-1/E-24, Mohan Cooperative Industrial Area, Mathura Road, New Delhi – 110044. The Petitioner is a generating company within the meaning of Section 2(28) of the Electricity Act, 2003 (“**the Act**”).
2. The Respondent is the Government of Sikkim, Energy & Power Department.
3. The Petitioner entered into an Implementation Agreement dated 03.09.2008, with the Respondent for setting up Hydro Electric Project in Tashiding District on Rangit river, of capacity 2 x 48.5 MW (“**Tashiding Hydro-Electric Project**” or “**THEP**” or “**Project**”). True copy of the Implementation Agreement is annexed and marked as **Annexure 1**.
4. In respect of the aforesaid, the Petitioner applied to Power Grid Corporation of India Limited (“**PGCIL**”) for grant of ‘Long Term Open Access’ for evacuation of power from the THEP as PGCIL is the Central

Transmission Utility under the Act and owns and manages the inter-state transmission system across India. PGCIL is a body corporate, which is vested with the functions of Central Transmission Utility as provided under Section 38 of the Act and is an inter-state transmission licensee authorized to grant connectivity to generators and also to allot open access for evacuation of power for generating stations to the grid.

5. In pursuance of the application by the Petitioner, PGCIL *vide* its communication dated 26.05.2009 forwarded its intimation for providing the Long Term Open Access to the Petitioner. In terms of Annexure 3 thereof, the dedicated part of the 'Transmission System', with reference to THEP, being "*Tingting – New Melli 220 KV D/c line weather twin moose conductor, one ckt via Tashiding, along with associated line bays.*", being routed through the proposed pooling point substation near Tashiding, was initially to be implemented by the Petitioner along with Tingting Project.
6. However, subsequently, in the Minutes of Meeting held on 28.12.2010 between the Petitioner and PGCIL along with other project developers, the Petitioner's scope of work was revised. The Petitioner's scope of work was limited to the construction of the Transmission system (drawl line) upto Tashiding pooling station near Tashiding 220 KV D/c line and accordingly rest of the transmission line from Tashiding pooling station near Tashiding 220KV D/c line to New Melli pooling station was removed/ taken out from the Petitioner's scope of the implementation of the transmission system. Accordingly, the implementation of the transmission line from Tashiding pooling station near Tashiding 220KV D/c line to New Melli pooling station was now under the scope of work of the Respondent. The relevant extract is reproduced below:

*"C. Transmission System under the scope of Government of Sikkim:
- Pooling station near Tashiding – New Melli 220 KV D/c with twin moose conductor."*

True copy of PGCIL's intimation dated 26.05.2009 is annexed and marked as **Annexure 2**.

The copy of the relevant extract of the Minutes of Meeting dated 28.12.2010 along with the forwarding letter dated 03.01.2011 issued by PGCIL is annexed and marked as **Annexure 3**.

7. With reference to the aforesaid, the Petitioner [*as a Long Term Transmission Customer ('LTCC')*] and PGCIL [*as 'CTU' / 'Inter State Transmission Licensee' ('ISTS Licensee')*] entered into a Long Term Access Agreement ("**LTAA**") for purposes of granting long term access to LTCC by ISTS, in accordance with the Central Electricity Regulatory Commission (Grant Of Connectivity, Long Term Access and Medium Term Open Access in Inter State Transmission And Related Matters) Regulations, 2009. As per Annexure 1 of the said LTAA, the Long Term Access ('LTA') with reference to THEP, was to commence from February 2014. It would be relevant to mention herein that by the said commencement date the works related to the 'Transmission System' for LTA were to be completed and implemented and accordingly the commencement date was to coincide and match with the time frame for completion of the Project by the Petitioner and declaration of the Commercial Operation Date ("**COD**") thereof, as indicated in the said Annexure to the LTAA. Further, in terms of Annexure 2 of the LTAA, and as had been earlier agreed upon between the parties herein in the aforesaid Minutes of Meeting dated 28.12.2010, the implementation of Transmission system (drawl line) from Tashiding Pooling station near Tashiding 220KV D/c line to New Melli Pooling station was not part of the Petitioner's scope of implementation of the transmission system.

True copy of the LTAA dated 19.10.2011 is annexed and marked as **Annexure 4**.

8. In terms of Annexure 3 of the LTAA, the pooling station near Tashiding to New Melli 220KV D/c with twin moose conductor was under the scope of the Respondent. The relevant extract of Annexure 3 of the LTAA is reproduced below:

“Transmission System under the scope of Govt. of Sikkim

- Pooling station near Tashiding – New Melli 220 KV D/c with twin moose conductor.”

9. Accordingly, the Transmission assets were to be implemented in the following manner:

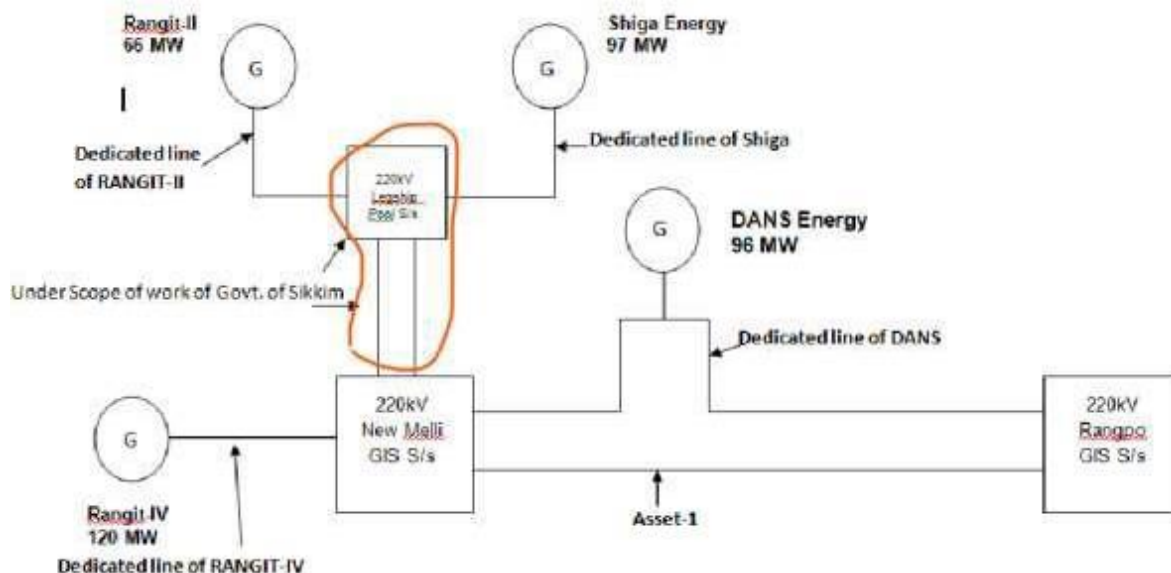

- 10.** Because of the Writ Petitions filed by local residents before the Hon’ble Supreme Court of India (which were transferred by the Supreme Court of India to the Hon’ble High Court of Sikkim), against the implementation and execution of the THEP, certain interim orders were passed by the Hon’ble High Court which affected the implementation of the THEP. As a result of such unforeseen circumstances, beyond the control of the Petitioner, the COD of THEP got extended beyond its scheduled date. The Petitioner had apprised the Respondent of the aforementioned aspect, in its letter dated 23.01.2015, which is annexed herewith and marked as **Annexure 5.**

11. Therefore, for the reasons stated hereinabove, the extension of the COD was never disputed by the Respondent or PGCIL.
12. In the meanwhile, the Petitioner and PGCIL herein entered into a Transmission Service Agreement (“TSA”) dated 30.01.2014, to govern the provisions of the inter-state transmission services. True copy of the TSA is annexed and marked as *Annexure 6*.
13. The Respondent and PGCIL executed a Memorandum of Understanding dated 22.04.2015 (“MOU”) whereby PGCIL, was appointed as the Project Management Consultant for the Respondent, to execute the implementation of the Legship Pooling Station to the New Melli 220 kV Pooling Station. Therefore, PGCIL was acting as an agent of the Respondent in terms of the MOU.
14. The Petitioner herein vide a series of communication, including Petitioner’s communications dated 05.03.2015, 18.03.2015, 07.04.2015, 21.04.2015, 23.06.2015, 05.08.2015 and 24.09.2015, informed PGCIL that the construction of THEP was progressing and had reached advanced stages, with the COD expected to be achieved in December 2016. In view of the above, since PGCIL was the Project Management Consultant and agent of the Respondent in terms of the MOU, the Petitioner requested PGCIL to carry out the work related to the construction of the Legship substation and the Transmission line from the Legship to New Melli on a priority basis to avoid any delay in power evacuation of THEP. It would be pertinent to mention herein that the said requests and repeated reminders of the Petitioner were never responded to by PGCIL. A copy of the letter dated 24.09.2015 was also sent to the Respondent.

True copies of communication dated 05.03.2015, 18.03.2015, 07.04.2015, 21.04.2015, 23.06.2015, 05.08.2015 and 24.09.2015

addressed by the Petitioner herein are collectively annexed and marked as **Annexure 7 (Colly.)**.

15. That, in the meantime, in the 10th Connectivity & LTA Meeting of Eastern Region held on 25.05.2015, it was discussed and recorded in the Minutes thereof, that the Commissioning schedule of THEP would be December 2016 and further that the Petitioner was constructing its scope of the dedicated 'Transmission System'. The said Minutes further recorded the request of the Petitioner to expedite the implementation of the Legship substation and Legship to New Melli Transmission line.

True copies of the Minutes of the Meeting dated 25.05.2015 along with its forwarding letter dated 02.07.2015 is annexed and marked as **Annexure 8**.

16. Taking note of the fact that PGCIL (acting as an agent of the Respondent) had yet not awarded the construction works of the Transmission System falling in its scope i.e. Legship Pooling Station – New Melli 220KV D/c line along with the Legship pooling station, and also further taking note that THEP was expected to achieve commissioning by December 2016, the CEA *vide* its communication dated 04.11.2015 also registered its request to PGCIL to start the aforesaid construction works at the earliest so as to complete the transmission line and the pooling station in the same time frame of the generation project i.e. December 2016.

True copy of the communication from the Central Electricity Authority dated 04.11.2015 is annexed and marked as **Annexure 9**.

17. In a meeting held on 23.11.2015 (being the Meeting on 'Power evacuation system for Jorethang HEP and Tashiding HEP in Sikkim constraints'), after considering the respective stands of the participants therein, it was agreed that PGCIL should expedite the commissioning of the Legship pooling station and the Legship – New Melli Transmission line, so as to

match the commissioning schedule of the Project, whose expected COD is December 2016. It was further agreed that in case of delay in completion of the Legship pooling station, the Legship – New Melli Transmission line may be bypassed at the Legship pooling station. Moreover, PGCIL agreed that the construction of GIS Bays would be accorded top priority so as to complete construction of the said bays along with THEP, i.e., on or before December 2016. The Minutes of this meeting were also sent to the Respondent by letter dated 24.11.2015.

True copy of the relevant extracts of the Minutes of the Meeting dated 23.11.2015 along with the forwarding letter dated 24.11.2015 issued by the CEA is annexed and marked as ***Annexure 10***.

18. The Petitioner vide its letters dated 29.12.2015 and 19.01.2016, once again informed the CEA and PGCIL (acting as the agent of the Respondent) respectively, that the expected COD of the said Project was December 2016 and also made a request that the works related to the Legship – New Melli Transmission line be matched with the completion of the said Project, which is expected to achieve COD in December 2016.

The copies of communications dated 29.12.2015 and 19.01.2016 addressed by the Petitioner herein are collectively annexed and marked as ***Annexure 11***.

19. In the meeting held on 04.02.2016 chaired by the Chief Engineer (PSPM), CEA, the Minutes whereof were recorded, PGCIL (acting as the agent of the Respondent) was advised to take up the construction of the Transmission line for Legship to New Melli & 2 No. associated GIS Bays at New Melli substation at the earliest as THEP was expected to be complete by December 2016.

True copy of the relevant extract of the Minutes of the Meeting dated 04.02.2016 along with the forwarding letter dated 19.02.2016 issued by the CEA is annexed and marked as **Annexure 12**.

20. Further, in another meeting held on 08.02.2016, chaired by Member (Hydro), CEA, the Petitioner informed the participants of the said meeting that the dry commissioning of THEP was scheduled for October 2016 and the wet commissioning for November 2016, with the unit likely to be commissioned by December 2016. Considering the said schedule of commissioning of THEP, PGCIL (acting as the agent of the Respondent) was once again requested to complete the "Legship" pooling station and the Transmission line from Legship pooling station to New Melli substation by September 2016.

True copy of the relevant extract of the Minutes of the Meeting dated 08.02.2016 along with the forwarding letter dated 23.02.2016 issued by the CEA is annexed and marked as **Annexure 13**.

21. In the 8th Meeting of the Joint Coordination Committee for High Capacity Corridor for IPPs in Eastern Region, with reference to THEP, it was observed that the Transmission System under the scope of work of the Respondent was to be expedited.

True copy of the relevant extract of the Minutes of the Meeting dated 16.02.2016 along with the forwarding letter dated 03.03.2016 issued by PGCIL itself is annexed and marked as **Annexure 14**.

22. The Petitioner *vide* its communications dated 02.03.2016 and 23.03.2016 brought to PGCIL's notice that the works related to Legship sub-station, 220KV D/c Transmission Line from Legship pooling station to New Melli substation, and the associated 2 Nos. GIS Bays at New Melli, had yet not been awarded by PGCIL.

True copies of communications dated 02.03.2016 and 23.03.2016 addressed by the Petitioner are collectively annexed and marked as ***Annexure 15.***

23. The aforesaid factum of the works relating to Legship – New Melli Transmission line being yet not awarded by PGCIL came to be further noted in the Minutes of the Meeting dated 01.04.2016 taken by the Member (PS), CEA. Considering the delay in awarding the Transmission line Project under the scope of work of the Respondent in relation to the THEP, the Petitioner requested for an interim arrangement, i.e., transmission line from THEP to Legship pooling station and Transmission line from Legship pooling station to New Melli substation be directly connected by bypassing the Legship pooling station to evacuate power from THEP. The said request was acknowledged and agreed by PGCIL to enable evacuation of power without any hold up. In view of the above, the CEA advised PGCIL to expedite the construction of 220KV D/c Legship – New Melli line and 220/132 KV Legship sub-station at the earliest so as to complete the same before December 2016 to avoid constraint of power evacuation from the THEP.

True copy of the Minutes of the Meeting dated 01.04.2016 along with the forwarding letter dated 06.04.2016 issued by the CEA is annexed and marked as ***Annexure 16.***

24. The Petitioner *vide* its communication dated 28.04.2016 addressed to the Respondent reminded that the works for the Transmission Line from Legship to New Melli have not been awarded by PGCIL. It was further stated that the Petitioner would have to bear an expenditure of about Rs. 10 crores every month for delay in evacuation of power after completion of THEP towards interest to project lenders (being 'Power Finance Corporation Limited' and 'IFCI Limited.') and overheads. In view of the above, the Respondent was requested to take immediate action for

completion of the Transmission Line. The relevant extract of the letter dated 28.04.2016 are reproduced below:

“Subject: Evacuation of Power from Tashiding Project, construction of 220 KV line from Legship to New Melli.

Dear Sir,

We thank you very much for your visit of your officers to our Project site on 24th of this month to assess the progress. The construction is in advanced stage and confident to achieve the COD by Dec 2016. The progress of the Project on all components is already submitted to the team.

We have started the construction of the Transmission Line from the Project to the Legship and plan to complete before end of July. We find the Transmission line from Legship to New Melli which is under the scope of Sikkim Govt. has been still not awarded by the Power Grid (executing entity) and we have not received any schedule of the completion of the line. Completion of this line is very important for evacuation and we informed the same to your dept. on many occasions starting from April 2015.

We like to bring to your kind notice that there will be an expenditure of around Rs 10 (ten) crores to the company for every month of delay in evacuation after completion of the project towards interest and overheads. Hence, we request your good selves to take required immediate action and complete the transmission line by Dec 2016 matching our completion of the project.

True copy of the communication dated 28.04.2016 addressed by the Petitioner is annexed and marked as **Annexure 17**.

25. The Petitioner's further repeated requests for completion of the Transmission works in the scope of work of the Respondent by December

2016 were again taken note of and recorded in the Minutes of the Meeting dated 18.05.2016, chaired by the Chief Engineer (HPM), CEA.

True copy of the relevant extract of the Minutes of the Meeting dated 18.05.2016 along with the forwarding letter dated 30.05.2016 issued by CEA is annexed and marked as **Annexure 18**.

26. That once again, in the Meeting of the Joint Coordination Committee for High Capacity Corridor for IPPS in Eastern Region (being the 9th Meeting) held on 10.06.2016, with reference to THEP, it was remarked that the Transmission System under the scope of work of the Respondent was to be expedited.

True copy of the relevant extract of the Minutes of the Meeting dated 10.06.2016 along with its forwarding letter dated 30.06.2016 issued by PGCIL itself is annexed and marked as **Annexure 19**.

27. That the interim arrangement of bypassing the Legship pooling station as agreed in the Minutes of the Meeting dated 01.04.2016 was reaffirmed in the Minutes of the Meeting dated 13.06.2016 of the 18th Standing Committee of Power System Planning of Eastern Region. With reference to the aforementioned interim arrangement of bypassing the Legship Pooling Station, it would be relevant to mention that PGCIL, acting as an agent of the Respondent, in the Minutes of the Meeting dated 13.06.2016 had informed that the Legship – New-Melli 220KV D/c line (which Transmission line was crucial even for implementing the interim arrangement of bypassing the Legship Pooling System) was being expedited, and may be completed by December 2016 and the line bays at New Melli by March 2017.

In the said Minutes, the parties also agreed to another additional interim arrangement, i.e. if the bays at New Melli for termination of Legship – New – Melli 220 KV D/c line are not ready, then a Line in-Line out (LILO)

of one circuit of New Melli – Rangpo 220 KV D/c line be implemented at a suitable location near New Melli with the same being further connected with Tashiding – New Melli line so as to form Tashiding – New Melli, Tashiding - Rangpo and New Melli - Rangpo 220 KV S/c lines.

The copy of the relevant extracts of the Minutes of the Meeting dated 13.06.2016 along with the forwarding letter dated 19.08.2016 issued by the CEA is annexed and marked as ***Annexure 20.***

28. The Petitioner sent a letter dated 21.06.2016 to the Respondent seeking information for signing the Connection Agreement with respect to the Inter State Transmission System and requesting the Respondent to consider the Petitioner's case on top priority basis as the Project would be ready for commissioning by December 2016.

True copy of the letter dated 21.06.2016 is annexed and marked as ***Annexure 21.***

29. The Petitioner once again requested that the Transmission line works in the scope of work of the Respondent be expedited and the completion thereof by December 2016, as recorded in the Minutes of the Meeting dated 01.09.2016, chaired by the Chairperson, CEA.

True copy of the relevant extracts of the Minutes of the Meeting dated 01.09.2016 is annexed and marked as ***Annexure 22.***

30. The aforesaid aspect of the Transmission line works falling in the scope of work of the Respondent being required to be expedited further came to be taken note of in the Minutes of the 10th Meeting of Joint Coordination Committee for High Capacity Corridor for IPPs in Eastern Region dated 30.09.2016.

True copy of the relevant extracts of the Minutes of the Meeting dated 30.09.2016 along with its forwarding letter dated 24.10.2016 issued by the Respondent itself is annexed and marked as **Annexure 23**.

31. Citing reference to the aforesaid meetings, the Petitioner addressed communications dated 03.10.2016 and 13.10.2016 to the CEA and the Respondent, respectively, highlighting that the aspect that the completion of the Transmission line works, falling within the scope of work of the Respondent, was vital to match with the commissioning schedule of THEP by December 2016, so as to avoid the loss of 1.17 Million units of clean energy every day and also the increase in the Interest During Construction (“**IDC**”) to the lenders of the Project, which would render THEP unviable. It would be pertinent to mention that in the said communications, the Petitioner also apprised the CEA and also the Respondent that the Petitioner expected to complete the Transmission line works, which fell within its scope, by December 2016.

The copies of the Petitioner’s communications dated 03.10.2016 and 13.10.2016 are collectively annexed and marked as **Annexure 24 (Colly.)**.

32. In the meeting dated 04.10.2016 chaired by the Chief Engineer (PSPM) to review the construction progress of Transmission system *inter alia* associated with THEP, it was made known that PGCIL had much belatedly awarded the 220KV D/c Legship – New Melli line in July 2016 to one M/s KEC, for the construction of approximately 10 km Transmission line, with detailed survey yet not complete. Taking note of the same, the Chief Engineer (PSPM) advised M/s KEC to submit an action plan within 1 week for completion of the Transmission line by 15.12.2016 and submit weekly reports of the status of the progress.

True copy of the relevant extracts of the Minutes of the Meeting dated 04.10.2016 along with the forwarding letter dated 13.10.2016 issued by the CEA is annexed and marked as **Annexure 25**.

33. Pursuant to the aforesaid meeting, the CEA addressed a communication dated 20.10.2016 to PGCIL, with a copy to the Respondent, expressing its regret that M/s KEC had not submitted any action plan, as was agreed to be done in the aforesaid Meeting dated 04.10.2016. Accordingly, the CEA requested PGCIL to look into the said matter so that the construction of the 220KV D/c Legship – New Melli line is completed on a top priority basis and that THEP gets commissioned as per the schedule in December 2016.

True copy of the communication dated 20.10.2016 addressed by the CEA is annexed and marked as **Annexure 26**.

34. The civil works, E & M works as also the MIV Installation of Units – 1 & 2 of the THEP stood completed by the Petitioner, which was so informed and recorded in the Minutes of the Meeting dated 03.11.2016, chaired by the Chairpersons, CEA [being a meeting to review the progress of works of the under construction (Private Sector) Hydro Electric Projects (above 25 MW)]. In the said Meeting it was further taken note that the testing of the units along with its likely commissioning would be done in December 2016. However, the main constraint was the Transmission line works, being in the scope of work of the Respondent which needed to be completed by December 2016. It was recorded that the main constraint is Transmission works for which intervention of the Government is needed and the Transmission line within the scope of work of the Respondent needs to be completed by December 2016.

True copy of the relevant extracts of the Minutes of the Meeting dated 03.11.2016 along with the forwarding letter dated 09.11.2016 issued by the CEA is annexed and marked as **Annexure 27**.

35. The Petitioner addressed a communication dated 07.11.2016 to the Respondent (with a copy to PGCIL) highlighting the poor progress of works on the Transmission lines falling within the scope of work of the Respondent, which aspect had also been emphasized by the CEA at various Joint Meetings, as aforementioned. By way of the said communication, the Petitioner herein stressed upon the timely completion of the Transmission lines up to New Melli substation as being extremely critical to the evacuation of power from THEP by December 2016/ January 2017.

True copy of communication dated 07.11.2016 addressed by the Petitioner is annexed and marked as ***Annexure 28***.

36. In furtherance of its earlier communication dated 13.10.2016 whereby the Petitioner requested for completion of the Transmission line from Legship to New Melli by December 2016, the Petitioner *vide* its communication dated 08.11.2016 informed the Respondent of the lack of progress of works at site, and further reiterated the aspect of completion of the balance Transmission line works as being critical for evacuation of power.

True copy of communication dated 08.11.2016 addressed by the Petitioner is annexed and marked as ***Annexure 29***.

37. That M/s KEC and PGCIL, after much delay, submitted the progress of Transmission line in the meeting dated 16.11.2016 chaired by the Chief Engineer (PSPM), CEA. A perusal of the said Minutes would show that PGCIL committed to complete the works by January 2017. Further it was recorded that the Petitioner's scope of work would be ready after December 2016 and PGCIL informed that the following were required to be resolved at the earliest to expedite the completion of the Project:
- (a) Road permit by the Respondent is awaited; and

(b) Non-availability of TAN No. from the Respondent.

True copy of the Minutes of the Meeting dated 16.11.2016 along with the forwarding letter dated 05.12.2016 issued by the CEA is annexed and marked as **Annexure 30**.

38. That in response to the Petitioner's aforementioned communication dated 07.11.2016, PGCIL, being the agent of the Respondent, *vide* its communication dated 29.11.2016, in utter disregard to its commitment made in the aforementioned minutes dated 16.11.2016, and without citing any change in the circumstances/ reasons for delay as had been taken by it in the said Minutes, which could lead to further delay, changed its stance by stating that it would make best efforts to complete the Transmission line by March 2017. PGCIL further informed the Petitioner that the Respondent never placed an order to execute the Transmission line from the Legship pooling station to the New Melli pooling station in September 2014. PGCIL further stated that after the award of contract initially there was a delay of 2-3 months due to commercial issues like road permit, TAN no., etc. which are attributable to the Respondent. PGCIL further stated that efforts were being made to complete the line by March 2017.

True copy of the communication dated 29.11.2016 addressed by the Respondent is annexed and marked as **Annexure 31**.

39. The Petitioner addressed a reply dated 12.12.2016 to PGCIL's aforementioned communication dated 29.11.2016, bringing to PGCIL's notice the various Joint Meetings held between the concerned parties wherein, *inter alia*, the aspect of the scheduled commissioning of THEP by December 2016 had been time and again highlighted. Citing references to the Minutes dated 16.11.2016, wherein, PGCIL has agreed for completion of transmission line by 2017, the Petitioner expressed its shock and surprise of PGCIL's stand as taken by the latter in its

communication dated 29.11.2016 of making best efforts to complete the Transmission line by March 2017. The Petitioner *vide* its communication dated 12.12.2016 brought to the specific notice of PGCIL that in case the line from Legship to New Melli was not completed in time, the same would result in a loss of approximately Rs. 10 crores per month for the Petitioner towards additional IDC besides loss of revenue against sale of power.

True copy of the communication dated 12.12.2016 addressed by the Petitioner is annexed and marked as ***Annexure 32***.

40. In the 11th Meeting of Joint Coordination Committee for High Capacity Corridor for IPPs in Eastern Region, with reference to the THEP, it was once again remarked that the Transmission System under the scope of work of the Respondent was to be expedited.

True copy of the relevant extracts of the Minutes of the Meeting dated 27.12.2016 along with the forwarding letter dated 02.02.2017 issued by PGCIL itself is annexed and marked as ***Annexure 33***.

41. The Petitioner *vide* its communication dated 29.12.2016 informed PGCIL, acting as agent of the Respondent that it had successfully completed the dry commissioning of one unit of THEP, with its second unit being planned to be completed by end of December, as mentioned in various Meetings. Further, PGCIL was also apprised that the 220 KV D/c Transmission line from THEP to Legship substation (falling within the scope of work of the Petitioner herein) was also expected to be completed by end of December 2016. In such circumstances, the Petitioner notified PGCIL that it was extremely critical that the Transmission line from Legship to New Melli being built by PGCIL, as agent of the Respondent is completed by January 2017, so as to enable the evacuation of power from THEP.

True copy of communication dated 29.12.2016 addressed by the Petitioner is annexed and marked as ***Annexure 34.***

42. In furtherance of its aforesaid communication dated 29.12.2016, the Petitioner by letter dated 04.01.2017 to the CEA, with a copy to the Respondent and PGCIL, notified the completion of the dry commissioning of both units as also the construction of the 220KV D/c Transmission line from THEP to Legship sub-station, which fell within the scope of work of the Respondent. By way of said communication, the Petitioner once again requested for the completion of the Transmission line from Legship substation to New Melli substation, which was required for the evacuation of power from THEP.

True copy of communication dated 04.01.2017 addressed by the Petitioner is annexed and marked as ***Annexure 35.***

43. The Petitioner reiterated in its communication dated 17.01.2017 to the Respondent that failure of completion of Transmission works falling under the scope of work of the Respondent shall result in a loss by virtue of the additional interest burden to the extent of Rs. 10 crores per month. The relevant extracts of the communication dated 17.01.2017 are reproduced below:

“We are pleased to inform that we have successfully completed the dry commissioning of both the units of our Tashiding (97 MW) Hydroelectric Project in Sikkim. The reservoir has been filled & tested and penstock charged.

Further, we have also completed the 220 kV D/c transmission line from Tashiding HEP to Legship substation. Hence as per our earlier commitment the main works have been completed by end December 2016.

Power from Tashiding HEP is ready for evacuation and can be evacuated once the transmission line from Legship to New Melli being built by Sikkim

government is completed. Hence, the completion of the transmission line from Legship s/s to New Melli station is critical.

In case of any delay, the company would incur an additional interest burden on the loan to the extent of Rs, 10 crores per month.

We sincerely request that the transmission line from Legship substation to New Melli substation required for power evacuation of our Tashiding HE Project can be completed at the earliest to avoid loss of Power and revenue both to the Project and to Sikkim state."

True copy of communication dated 17.01.2017 addressed by the Petitioner is annexed and marked as **Annexure 36**.

44. The Petitioner sent a communication dated 23.01.2017, to CEA stating that the dry commissioning of both the units as well as the 220 KV D/c Transmission line from Tashiding HEP to Legship substation has been successfully completed. The Petitioner further reiterated that the evacuation of power can only be achieved if the Transmission line from Legship substation to New Melli substation can be immediately completed by the Respondent/ PGCIL/ M/s KEC and therefore the completion of the said Transmission line is critical, failing which there will be loss of green power and revenue as well as an additional interest burden on the Petitioner of approximately Rs. 7 crores per month.

A true copy of the communication dated 23.01.2017 is annexed and marked as **Annexure 37**.

45. By communication dated 06.02.2017 the Petitioner requested the Chief Electrical Inspector of the Respondent for the issuance of Clearance Certificate for First Charging as the entire installation of the powerhouse, sub-station, switchyard and 220KV D/c line has been constructed and tested.

A true copy of the communication dated 06.02.2017 is annexed and marked as ***Annexure 38***.

46. As brought out above, that though PGCIL, as an agent of the Respondent, had initially committed to complete the Transmission line works under the scope of work of the Respondent by December 2016, and then by January 2017 and further by March 2017, it had even failed to start the construction of the Legship Pooling station as on 13.02.2017, which aspect is so borne out from the Minutes of even date taken by the Member (PS), CEA.

True copy of the Minutes of the Meeting dated 13.02.2017 along with its forwarding letter dated 21.02.2017 issued by CEA is annexed and marked as ***Annexure 39***.

47. With reference to the aforesaid, it would be worth mentioning that in the 12th Meeting of the Joint Coordination Committee of High Capacity Corridor for IPPs in Eastern Region, with reference to THEP, it was remarked that the completion of the Transmission System under the scope of work of the Respondent is to be expedited for completion, which is expected by May 2017.

True copy of the relevant extract of the Minutes of Meeting dated 27.03.2017 along with its forwarding letter dated 09.05.2017 issued by PGCIL itself is annexed and marked as ***Annexure 40***.

48. By communication dated 28.03.2017, from Ex Chief Engineer, CEA to the Petitioner stating that the Transmission line of the Petitioner is ready but it is yet to be terminated at the Legship pooling point of PGCIL.

A true copy of the communication dated 28.03.2017 is annexed and marked as ***Annexure 41***.

49. That the Petitioner submitted an Item Wise Compliance Report dated 03.04.2017 stating that the PLCC Test and Fault Locator Test can only be performed after both the ends of the Transmission line are properly terminated/ connected.

A true copy of the communication dated 03.04.2017 is annexed and marked as ***Annexure 42.***

50. The gross delays in the execution of the works by PGCIL was once again notified by the Petitioner in its communications dated 10.04.2017, 13.04.2017 and 01.05.2017, wherein, the aspect of the works, falling within the scope of work of Respondent, being only half completed had been highlighted, and which in effect was resulting in generation/ revenue loss of more than Rs. 100 crores. The relevant extract of the letter dated 13.04.2017 is reproduced below:

Subject: Tashiding HE Project, Sikkim- Evacuation of Power

Dear Sir,

This is further to our letter no SEPL/TSG/E&M/11/15/026 dated 17th January 2017 vide which we had requested your kind support and help so that the transmission line from Legship to New Melli could be completed at the earliest.

As already informed, we have successfully completed the dry commissioning of both the units of our Tashiding (97 MW) Hydroelectric Project in December 2016 itself. However, on account of the non completion of the transmission line from Legship to New Melli, we are unable to evacuate power.

As per the minutes of the meeting of the 16th Standing Committee on Power System Planning of Eastern Region held on 02.05.2014 at NRPC, New Delhi, it was deliberated that

"Transmission system of Tashiding HEP(97 MW):-

- **Immediate Evacuation System (under the scope of Generation Developer)**
 - Tashiding - Legship 220kV D/c line
- **Common Transmission System under the scope of Govt. of Sikkim**
 - Establishment of 220kV substation at Legship
 - Legship - New Melli 220kV D/c with twin moose conductor"

As per above, Sikkim Government has to construct the transmission line from Legship to New Melli. Sikkim government had placed an order on PGCIL for the transmission line from Legship substation to New Melli substation in February 2015 under the Comprehensive Scheme. PGCIL in July 2016 subcontracted the transmission line work to KEC.

Unfortunately, the progress of the transmission line from Legship to New Melli is still slow. As per the contract placed by PGCIL on KEC this transmission line had to be completed by March 2017. We understand approximately 50% of the total work has been completed till date. A concentrated effort from Sikkim Government/PGCIL/KEC to resolve all the local issues & necessary mobilisation of required manpower would definitely expedite the progress of work.

You would appreciate if the work is not completed before beginning of May 2017 the monsoon season would be missed resulting in generation/revenue loss of more than Rs 100 crore. Further we are already suffering IDC charges of Rs 10 crore/month since December 2016.

We again sincerely seek your support and cooperation so that the Tashiding HE project could start generation before the monsoon commences to avoid loss of Power and revenue both to the Project and to Sikkim state.

True copy of the communications dated 10.04.2017, 13.04.2017 and 01.05.2017 addressed by the Petitioner are collectively annexed and marked as ***Annexure 43 (Colly.)***

51. The aforesaid stance of the Petitioner concerning the blatant and glaring delays of PGCIL, was further corroborated and fortified in the 13th Meeting of Joint Coordination Committee for High Capacity Corridor for IPPs in Eastern Region, which in reference to THEP, remarked that the COD of the said Project was waiting on account of non-commissioning of Legship – New Melli Transmission line and Bays at New Melli, being in the scope of work of the Respondent, and which was now expected by August 2017.

The copy of the relevant extracts of the Minutes of the Meeting dated 16.06.2017 along with the forwarding letter dated 08.08.2017 issued by PGCIL itself is annexed and marked as ***Annexure 44.***

52. By communication dated 28.04.2017, the Chief Electrical Inspector of the Respondent granted statutory approval for first charging of the THEP to the Petitioner.

True copy of the communication dated 28.04.2017, is annexed and marked as ***Annexure 45.***

53. The Petitioner sent reminders dated 02.06.2017 and 09.08.2017 to the Respondent to provide clarity on the information required to be furnished for signing the Connection Agreement.

True copy of the communication dated 02.06.2017 and 09.08.2017 is annexed and marked as ***Annexure 46 (Colly.)***

54. The Petitioner *vide* its communication dated 19.06.2017 requested PGCIL, as an agent of the Respondent, to provide the current status of

the Transmission line works from the Legship sub-station to the New Melli sub-station along with the target date of completion.

True copy of the communication dated 19.06.2017 addressed by the Petitioner is annexed and marked as **Annexure 47**.

55. That in response to the Petitioner's aforesaid communication dated 19.06.2017, PGCIL *vide* its communication dated 21.06.2017 once again gave a fresh commitment (which commitment in any case was in utter breach of its earlier commitment) of expecting to complete the transmission line works by 15.07.2017.

True copy of communication dated 21.06.2017 addressed by PGCIL is annexed and marked as **Annexure 48**.

56. By communication dated 18.08.2017, the Petitioner informed the Respondent that PGCIL has failed to complete the Transmission line works and that the continuous and repeated breaches has resulted in the Petitioner accruing losses, including generation loss and IDC from January 2017 onwards. The Petitioner further stated that it has already lost revenue of around Rs. 100 crores from January 2017 to end of August 2017 due to non-completion of the Transmissions line and in case Transmission line completion is extended to end of September, the additional revenue loss of around Rs. 23 crores will be incurred. The Petitioner also informed the Respondent that the Project has become a stressed asset due to non- completion of the said Transmission line.

True copy of the communication dated 18.08.2017 addressed by the Petitioner is annexed and marked as **Annexure 49**.

57. In the meantime, the Petitioner and the Respondent entered into a Connection Agreement dated 04.09.2017 for connection of the dedicated 220KV D/c Transmission line of THEP facility to use the Respondent's

Transmission system to transit electricity to and, or, from the facility through the Intra-State Transmission System from the date of commissioning of the 220 KV D/c Twin Moose Transmission line from the Legship pooling station (Tingbong) to the 220 KV D/c pooling station of CTU at New Melli.

True copy of the Connection Agreement dated 04.09.2017 is annexed and marked as ***Annexure 50.***

58. Minutes of Meeting of the 36th Technical Coordination/ Eastern Regional Power Committee dated 13.09.2017 and 14.09.2017 recorded the Interim Agreement on account of anticipated delay in commissioning of Legship pooling station and 2 No. 220 GIS Bays at New Melli substation.

True copy of relevant extracts of the Minutes of Meeting dated 13.09.2017 and 14.09.2017 are annexed and marked as ***Annexure 51 (Colly).***

59. The Electrical Inspectorate of the Respondent sent a letter dated 25.09.2017 noting that the Transmission line of THEP under the Petitioner's scope is ready and temporarily connected to Tower 1 of Powergrid, to be terminated at the pooling point at New Melli of Powergrid revealing the delay.

True copy of the Letter dated 25.09.2017 is annexed and marked as ***Annexure 52.***

60. By communications dated 25.09.2017 and 26.09.2017, sent by the Petitioner to the Electrical Inspectorate of the Respondent, the Petitioner stated *inter alia* that the Petitioner has complied with the instructions of the Electrical Inspectorate in communication dated 25.09.2017 and has removed the bamboo, debris and mud from the tower footings.

True copy of the communications dated 25.09.2017 and 26.09.2017 are annexed and marked as **Annexure 53 (Colly.)**.

61. By communication dated 26.09.2017, the Respondent approved the energizing of 220kV D/c Transmission line of 2 x 48.5 MW, THEP as required under Regulation 43 of the Central Electricity Authority (Measures Related to Safety and Electric Supply) Regulations, 2010.

True copy of the communication dated 26.09.2017 is annexed and marked as **Annexure 54**.

62. That after gross and inordinate delay as demonstrated above, the works of 220KV D/c Legship Pool (Tingmoo) to New Melli Transmission lines were completed on 10.10.2017, which came to be notified by PGCIL *vide* its communication of even date.

True copy of communication dated 10.10.2017 addressed by the PGCIL is annexed and marked as **Annexure 55**.

63. Pursuant thereto, the Petitioner declared COD of both the Units of THEP on 06.11.2017. In this regard, true copy of communication dated 06.11.2017 addressed to CEA is annexed and marked as **Annexure 56**.

64. It is abundantly clear from the above that the Transmission line from Legship to New Melli was within the scope of work of the Respondent, and the Respondent entered into the MOU dated 22.04.2015 with PGCIL for implementing the said Transmission line as Respondent's agent and Project Management Consultant.

65. On account of the gross and inordinate delay in implementation of the Transmission line from Legship substation to New Melli substation, the Petitioner approached the Hon'ble Central Electricity Regulatory Commission ("**Hon'ble CERC**") under Section 79(1)(f) read with 79(1)(c)

of the Act, on 28.02.2018, to adjudicate the grievance of the Petitioner i.e. the claim of compensation for loss suffered by the Petitioner on account of the failure to match the completion of the Transmission line system with the completion of THEP by December 2016.

True copy of the petition filed by the Petitioner before the Hon'ble CERC (without Annexures) is annexed and marked as **Annexure 57**.

66. By order dated 8.12.2021, the Hon'ble CERC did not find it appropriate to refer the dispute to arbitration.

True copy of the order dated 08.12.2021 is annexed and marked as **Annexure 58**.

67. The Hon'ble CERC by order dated 06.06.2022 held, *inter-alia*, as follows:

“30. We observe that in the letter dated 13.4.2017 the Petitioner had reiterated that Government of Sikkim was to construct the transmission line from Legship to New Melli for which the Government of Sikkim had given the contract to PGCIL.

31. We have gone through the series of letter exchanged between the Petitioner and PGCIL, Ministry of Power, CEA and Government of Sikkim. We note that from the very beginning, the Petitioner was well aware that the transmission line for the evacuation of power from its project was within the scope of Government of Sikkim. In fact, in its letter dated 28.4.2016 addressed to the Government of Sikkim, the Petitioner has specifically stated that PGCIL is an executing agency for the completion of transmission line. The same was also reiterated by the Petitioner in its letter dated 13.4.2017.

32. It is not in dispute that PGCIL had entered into the MoU dated 22.4.2015 with Government of Sikkim. The Petitioner was aware that the

Legship-New Melli transmission assets were being implemented by Respondent No.1 as per the MoU dated 22.04.2015 entered into between Respondent No.1 and the Government of Sikkim. It is a settled law under the Contract Act that only parties to a contract can enforce or be subject to the benefits or obligations under that contract. The privity of contract is the relationship that exists between the parties to an agreement. The doctrine of privity of contract provides that only a party to a contract has right to sue to enforce the contract. In other words, the doctrine of privity of contract provides that a contract confirm the right and imposes liability only on its contracting parties any third party cannot sue or be sued under the terms of the contract.

33. Section 230 of the Indian Contract Act, reads as under:

"230. Agent cannot personally enforce, nor be bound by, contracts on behalf of principal-In the absence of any contract to that effect, an agent cannot personally enforce contracts entered into by him on behalf of his principal, nor is he personally bound by them. Presumption of contract to contrary. Such a contract shall be presumed to exist in the following cases:-

- (1) where the contract is made by an agent for the sale or purchase of goods for a merchant resident abroad;*
- (2) where the agent does not disclose the name of his principal;*
- (3) where the principal, though disclosed, cannot be sued."*

34. Under Section 230 of the Indian Contract Act, it is laid down that unless a contract so provides, an agent cannot be bound by or enforce the contract personally, where it has acted for his principal. Therefore, if a third party knows the existence and identity of the principal, then all legal liability lies with the principal. The only exception to this is when an agent exceeds his or her authority. In that case, the agent has not acted with authority and becomes personally responsible to the third party. If the agent did not have authority, but the principal later ratifies the contract, then the principal will be liable for the contract.

35 In the present case, the Petitioner was well aware that the PGCIL was merely an executing entity and the scope of work for the subject transmission line was under Government of Sikkim. Therefore, PGCIL cannot be held liable for the delay in execution of Legship pooling station and transmission line from Legship to New Melli.”

...

“37. The Petitioner vide the amended petition has claimed compensation from the Respondent No.2, Government of Sikkim for delay of transmission assets. We observe from the LTA intimation that the assets under dispute (Legship pooling station and transmission line from Legship to New Melli) were originally under the scope of the Petitioner as a dedicated transmission system. Respondent No. 2 has submitted that it was the Petitioner, who citing difficulty in constructing the said transmission system, requested Government of Sikkim to get it included in the comprehensive scheme. This implies that the assets came under the scope of Government of Sikkim subsequently as recorded in the LTA Agreement. We observe that the transmission assets under dispute are a part of intra-state transmission system. The Petitioner has entered into Connection Agreement with the Power department, Government of Sikkim on 4.9.2017. We observe that the jurisdiction for any dispute vis-a-vis the intra-state transmission system lies with the concerned State Commission. Therefore, the Petitioner is at liberty to approach the Appropriate Commission for adjudication of the dispute relating to the intra-state transmission system.”

68. Accordingly in compliance with the order of the Hon’ble CERC, the Petitioner is approaching this Hon’ble State Commission.
69. It is clear from the above facts that failure to complete the Transmission line from Legship substation to New Melli substation, which was within the scope of work of the Respondent, within the agreed time period to

coincide with the COD of the Project has caused colossal losses to the Petitioner.

70. It is submitted that to pay the said IDC and other charges, so as to prevent the account from being declared a 'Non-Performing Asset' by the lenders, the Petitioner was compelled to obtain additional loans. The said additional liabilities, *inter alia*, being 'Short Term Loans' as also the difficulties being faced by the Petitioner to service the lenders' dues have arisen solely on account of breach and delay in implementation of the Transmission line works within the scope of work of the Respondent.
71. The cause of action to file the present Petition arose on 01.01.2017 when there was a gross and inordinate delay in completing the Transmission line works falling within the scope of work of the Respondent, which resultantly delayed the evacuation of power from THEP from beginning of January 2017.
72. The Petitioner approached the Hon'ble CERC seeking for the adjudication of the disputes. The Hon'ble CERC, heard the grievance of the Petitioner and *vide* order dated 06.06.2022 granted liberty to the Petitioner to approach the concerned State Commission for the adjudication of the dispute and observed that transmission assets under dispute are a part of intra-state transmission system and the jurisdiction for any dispute vis-a-vis the intra-state transmission system lies with the concerned State Commission.
73. The Petitioner was under the impression that the Hon'ble CERC has the jurisdiction to hear the dispute due to which the Petitioner was unable to approach this Hon'ble Commission. The Petitioner is directed by the Hon'ble CERC to approach this Hon'ble Commission for the adjudication of disputes.

74. The Petitioner, through its counsel, sent a letter dated 16.12.2022 to this Hon'ble Commission stating, inter-alia, the losses suffered by the Petitioner due to the delay in completion of the transmission line from Tashiding- Pooling Station to New Melli Pooling Station by the Energy and Power Department, Government of Sikkim, and requesting this Hon'ble Commission to refer the matter to arbitration under the provisions of Section 86 of the Act, for proper and effective adjudication of the matter. True Copy of the Letter dated 16.12.2022 has been annexed as ***Annexure 59***.
75. The Hon'ble Commission *vide* letter dated 21.01.2023 replied to the aforesaid letter dated 16.12.2022 of the Petitioner, stating that the Petitioner shall file the petition duly following the procedure as laid down in the Sikkim State Electricity Regulatory Commission (Conduct of Business) Regulations, 2012, along with the prescribed fees (as per schedule) and other supporting documents as per the said regulations. True Copy of the reply dated 21.01.2023 has been annexed as ***Annexure 60***.
76. Therefore, the Petitioner has suffered severe losses and damages due to failure to complete the Transmission line falling within the scope of work of the Respondent to match with the commissioning of the Project in December 2016 and the Petitioner is liable to be compensated for the same.
77. By the present Petition, the Petitioner is *inter alia* claiming a sum of Rs. 331.42 crores (along with interest thereon), from the Respondent for financial loss suffered by the Petitioner, on account of delay in implementation and completion of the Transmission Line from Legship substation to New Melli substation falling under the scope of the Respondent's obligations.

78. Under Section 86(1)(f) read with Section 158 of the Electricity Act, 2003, this Hon'ble Commission is empowered to refer the present dispute to arbitration. However, in view of the fact that a judicial member is not present on the Hon'ble Commission, this Hon'ble Commission may be pleased to pass an order referring the disputes raised in the present Petition to an Arbitral Tribunal consisting of 3 (three) arbitrators under Section 86(1)(f) read with Section 158 of the Act.
79. The Petitioner also prays that in the event this Hon'ble Tribunal is pleased to refer the present dispute to Arbitration in accordance with the Section 86(1)(f) read with Section 158 of the Act, the present petition may be treated as the Statement of Claims to be filed before the Hon'ble Arbitral Tribunal and the reliefs sought in the present Petition may be treated as the reliefs sought in the Arbitral proceedings before the Hon'ble Arbitral Tribunal.
80. It is submitted that on account of the aforesaid gross and inordinate delay by the Respondent in completing the Transmission line works falling within the scope of work of the Respondent, which resultantly delayed the evacuation of power from THEP from beginning of January 2017 up to 10.10.2017, the Petitioner has suffered financial loss to the tune of Rs. 112.39 crore on account of loss of revenue in commencement of the Long-Term Access granted to the Petitioner, due to delay in implementation of the 'Transmission System' falling in the scope of work of the Respondent. In this regard it is submitted that if the Transmission line in the scope of work of the Respondent was completed by December 2016 coinciding with the completion of THEP, the Petitioner could have sold the power and generated revenue from such sales. Therefore, such loss is attributable directly to the actions, omissions, breaches and defaults of the Respondent.

True copy of the computation chart of the financial loss along with the supporting documents, namely 'Detailed Project Report' of March 2009

and 'Project Information Memorandum' of October 2011 as also the month wise rate at 'Indian Energy Exchange' for the relevant period i.e., January 2017 to October 2017 are collectively annexed and marked as ***Annexure 61 (Colly.)***

81. Without prejudice to the aforesaid, it is further submitted that the THEP is financed by consortium of lenders, from whom the Petitioner has availed loan facility of Rs. 804.15 crores and cumulative redeemable preference shares (CRPS) facility of Rs. 25 crores. In terms of the financing documents, the Petitioner is required to pay interest during construction (IDC) to the lenders. The delay in building and completing the Transmission line within the scope of work of the Respondent resulted in delay of the COD of the Project and therefore, the Petitioner suffered a loss to the tune of Rs. 101.59 crores, which includes the following amounts (i) Rs. 87.94 crores towards IDC charges of the Petitioner to its lenders under the financing documents; (ii) Rs. 13.95 crores towards the preliminary and pre-operative expenses and additional claims of contractors engaged in the THEP, on account of delay in commencement of the Long Term Access granted to the Petitioner, due to delay in implementation of the Transmission system falling in the scope of work of the Respondent. The aforesaid amount of Rs. 101.59 crores along with interest of Rs. 117.44 crores at the rate of 15% per annum compounded annually from the COD till April 30, 2023, aggregates to Rs. 219.03 crores.

True copy of the certificate dated May 15, 2023 issued by B Luthra Associates, Chartered Accountants certifying the following losses to the Petitioner, as aforesaid, for the relevant period, i.e. January 2017 to October 2017 is annexed and marked as ***Annexure 62.***

Particulars	INR in Cr.
-------------	------------

A. Interest during construction (IDC) etc. payable to the lenders under the financing documents.	87.94
B. Preliminary and pre-operative expenses and additional claims of contractors.	13.65
C. Total Amount (A+B)	101.59
D. Interest on amount at (C) @15% per annum compounded annually till April, 2023	117.44
Grand Total (C+D)	219.03

82. The contents of the present Petition are bonafide and in the interest of justice. The present Petition is filed pursuant the directions of the Hon'ble CERC to approach the Ld. State Commission as the matter pertains to Intra State Transmission of Electricity which is within the jurisdiction of the Ld. State Commission.
83. It is submitted that the Petitioner has already suffered grave loss and if the issues in the present Petition are not considered the same would impact the operations of the Project which is an essential utility service for the State of Sikkim as well as other consumers in India where the power is supplied from the Project at a highly subsidized rate.
84. The Petitioner reserves the right to amend the Petition, file additional documents and urge additional grounds in support of the reliefs claimed before this Hon'ble Commission.

PRAYER

In the view of the aforementioned facts and circumstances, it is therefore, most respectfully prayed that this Hon'ble Commission may be pleased to:

- a) Pass an order directing the Respondent to pay a sum of Rs. 112.39 crores, being the financial loss suffered by the Petitioner on account of loss of revenue in commencement of the Long-Term Access granted to

the Petitioner, due to delay in implementation of the 'Transmission System' falling in the scope of work of the Respondent along with interest on the same till the date of payment of the amount by Respondent to the Petitioner;

- b) Pass an order directing the Respondent to pay a sum of Rs. 219.03 crores, including the following (i) Rs. 87.94 crores towards IDC charges of the Petitioner to its lenders under the financing documents; (ii) Rs. 13.95 crores towards the preliminary and pre-operative expenses and additional claims of contractors engaged in the THEP, on account of delay in commencement of the Long Term Access granted to the Petitioner, due to delay in implementation of the Transmission system falling in the scope of work of the Respondent; and (iii) Rs. 117.44 crores being the interest on amounts mentioned at (i) and (ii), at the rate of 15% per annum compounded annually from the COD till April 30, 2023, along with additional interest till the date of payment of the amount by Respondent to the Petitioner;
- c) Award the costs of the present proceedings (including fees, legal and other expenses) to the Petitioner; and
- d) Pass any such other orders as this Hon'ble Commission may deem fit and proper in the facts and circumstances of the present case.

PETITIONER

Through:



**Hardeep Sachdeva/ Kamal Shankar/ Abhyudai Singh/
Swati Sharma/ Tushar Dutta/ Devyani Jowel/
Maaz Ahmed**

Counsels For Petitioner

AZB & Partners

A-8, Sector 4, Noida, Uttar Pradesh

Email Id: abhyudai.singh@azbpartners.com

Phone No: +91-9968821409

Place: New Delhi

Date: .08.2023

BEFORE THE STATE ELECTRICITY REGULATORY COMMISSION,

SIKKIM

FILING NO. _____

CASE NO. P-01/Adj OF 2023

In the matter of:

**A PETITION UNDER SECTION 86(1)(F) OF THE ELECTRICITY ACT, 2003
TO ADJUDICATE THE DISPUTES BETWEEN THE PETITIONER AND THE
RESPONDENT**

And in the matter of :

Shiga Energy Private Limited

Having its office at:

10th Floor, DLF Building No. 8,

Tower – C, DLF Cyber City Phase – II,

Gurugram 122022

Haryana

...Petitioner

VERSUS

Government of Sikkim,

Energy & Power Department,

Through its Secretary

Kazi Road,

Gangtok – 737101,

Sikkim

...Respondent

AFFIDAVIT

I, Sh. Shishir Sharma, (S/o) Sh. Ram Abhilash Sharma, aged about 41 years, residing at Flat No. 1B, Tower- 17, Rail Vihar, Sector- 56, Gurugram- 122011, the deponent named above do hereby solemnly affirm and state on oath as under :-

1. That the deponent is the Vice President who is authorised as per the board resolution of the Petitioner dated 03.06.2022 and is acquainted with the facts deposed below.
2. I, the deponent named above do hereby verify that the contents of the Paragraph Nos. 1 of the affidavit and those of the Paragraph No. to of the accompanying petition are true to me personal knowledge and those of the Paragraph Nos. to of the accompanying petition are based on the perusal of the records and those of the Paragraph Nos. to of the accompanying petition are based on information received and those of the Paragraph Nos. to of the accompanying petition are based on the legal advice which I believe to be true and verify that no part of this Affidavit is false and nothing material has been concealed.

DEPONENT

VERIFICATION

Solemnly affirmed before me on this day of 2023 at AM/ PM by the deponent who has been identified by the aforesaid Advocate. I have satisfied myself by examining the deponent that he understood the contents of the Affidavit which has been read over and explained to him. He has been explained about Section 193 of the Indian Penal Code that whoever intentionally gives false evidence in any of the proceedings of the Commission or fabricates evidence for purpose of being used in any of the proceedings shall be liable for punishment as per law.

DEPONENT

(Identified by)